

SUBURBAN LAND RESERVE INC
58:035:0117

WAGSTAFF INVESTMENTS LLC
58:035:0116

PROPOSED PHASE E2
141.123
3.240 Acres

PROPOSED PHASE E1
721.778
16.570 Acres

RIVERSIDE DRIVE

IRON BLOSSOM DRIVE

WANDER PHASE D3 SUBDIVISION

WANDER PHASE C2 SUBDIVISION

JORDAN PROMENADE VILLAGE 1 PLAT B-3

BRIDGEWATER STREET

JORDAN PROMENADE VILLAGE 1 PLAT B-2

MEANDERING WAY

BRUSHY CANYON STREET

MEADOW SPRING AVENUE

120 S.
120 E.

WANDER AVENUE

200 S.
120 E.

275 S.
120 E.

325 S.
120 E.

365 S.
120 E.

POLARIS DRIVE

CROWN POINT DRIVE

INLET SPRINGS DRIVE

WANDER PHASE D2 SUBDIVISION

160 S.
20 E.

COPPER CANYON LANE

REDWOOD ROAD

CLAYTON PROPERTIES GROUP II INC
58:038:0055

400 SOUTH STREET

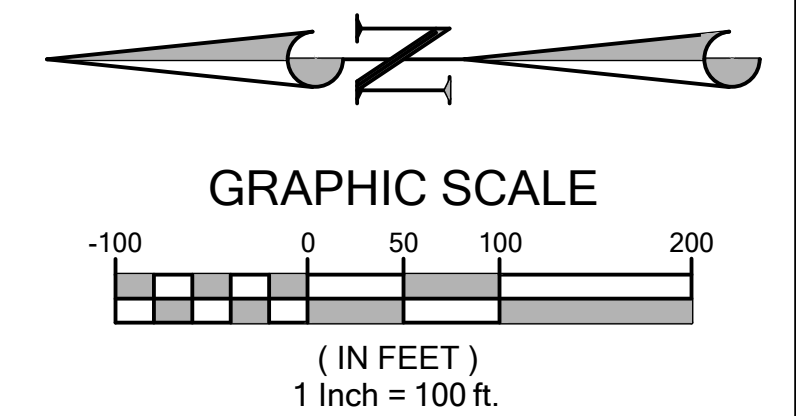

PERIGEE
CONSULTING
CIVIL • STRUCTURAL • SURVEY

9089 SOUTH 1300 WEST, SUITE 160
801.628.6004 TEL. 801.590.6811 FAX
WWW.PERIGEECIVIL.COM

CITY ENGINEER DATE

NO.	DATE	DESCRIPTION	BY	APPX.

DESIGNED BY: MB	DATE:	REV:
DRAWN BY: CHD	SOLUTION NO:	
SUBMITTED BY:	CONTRACT NO:	
FILE NAME:	PLotted BY:	PLotted DATE:
SIZE: A3		

WANDER PHASE E1 & E2
SUBDIVISION EXCEPTION
EXHIBIT

SHEET NUMBER

1 OF 1

DRAWING NAME
EXHIBIT